Describing network congestion and blocking with an analytic queueing network model

Carolina Osorio and Michel Bierlaire

Transport and Mobility Laboratory, EPFL

7th STRC Swiss Transport Research Conference

September 2007

Outline

- project objectives
- finite capacity queueing network framework
- model description
- case study: hospital patient flow
- current work: traffic flow of Lausanne

Overall objectives

Evaluate and improve network performance:

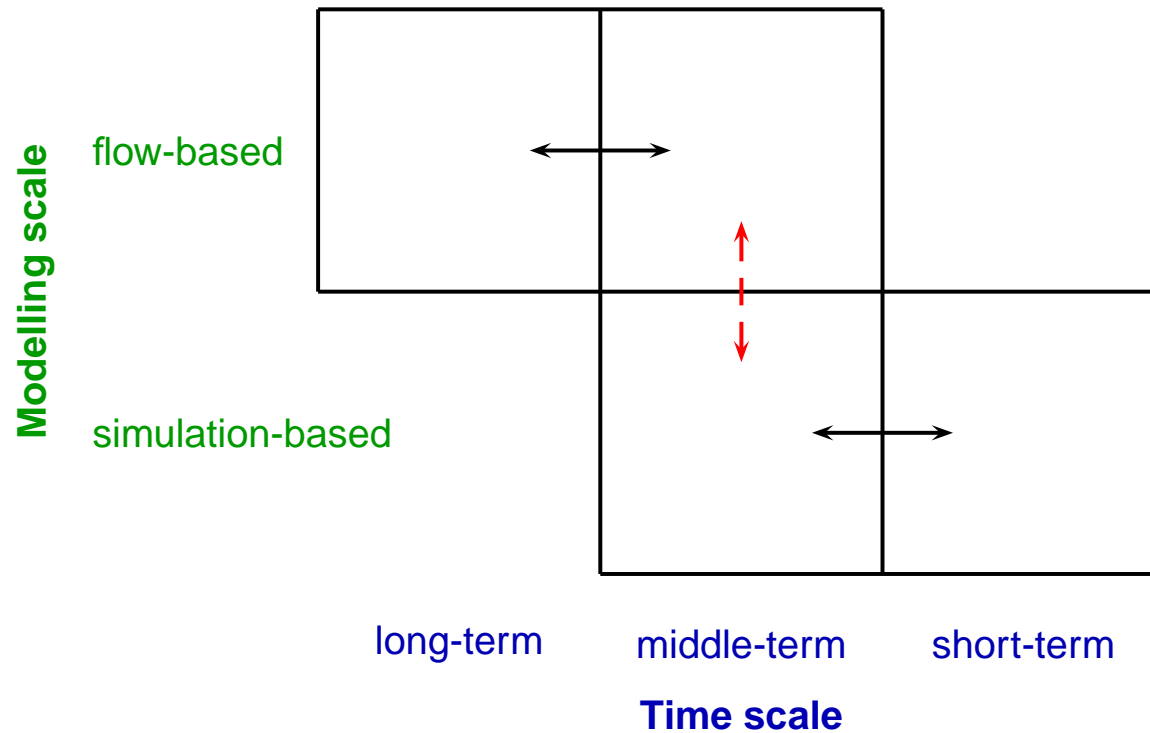

Current presentation: definition of the aggregate analytic model

Finite capacity networks

Aim: evaluate and improve network performance

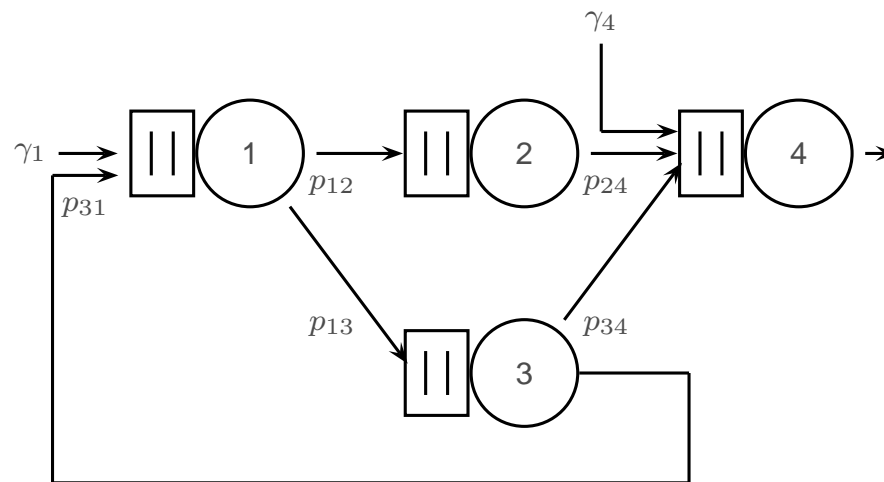

How can we model these networks?

Approach: queueing theory.

Queueing networks

Jackson networks

- infinite buffer size assumption
- violated in practice

Between-queue correlation structure

- complex to grasp
- helps explain: blocking, spillbacks, deadlocks, chained events

If these events want to be acknowledged:

finite capacity queueing networks

Finite capacity queueing networks FCQN

Main application fields:

- software architectures performance prediction
- telecommunications
- manufacturing systems

More uncommon applications:

- pedestrian flow through circulation systems
- prisoner flow through a network of prisons with varying security levels
- hospital patient flow
- traffic flow

Queueing: framework

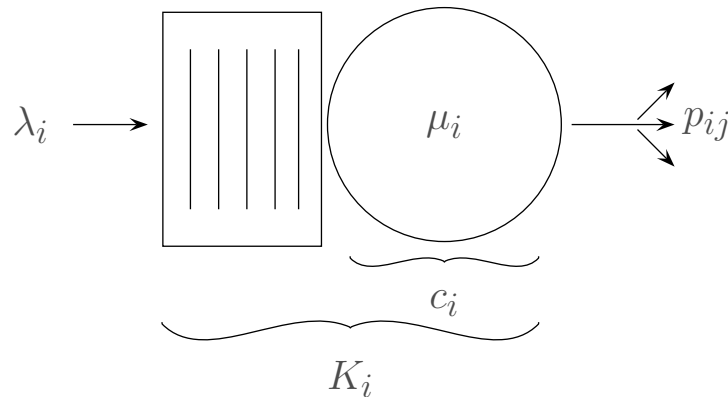

- c_i parallel servers
 - K_i total capacity: nb serveurs + queueing slots
 - λ_i : average arrival rate
 - μ_i : average service rate
 - p_{ij} : transition probabilities (routing)
-
- station (queue)
 - job

FCQN methods

Evaluate the main network performance measures using the **joint stationary distribution**.

State of the network: number of jobs per station.

$$\pi = (P(N_1 = n_1, \dots, N_S = n_S), \quad (n_1, \dots, n_S) \in (\mathcal{S}_1, \dots, \mathcal{S}_S))$$

- 1. Closed form expression
 - 2. Exact numerical evaluation
- } small networks (+ specific topologies)

A more flexible approach:

- 3. **Approximation methods: decomposition methods**

Decomposition methods

By decomposing we can aim at analysing:

- arbitrary topology and size

Method description

1. decompose into subnetworks
2. analyse each subnetwork independently
3. evaluate the main performance measures

Subnetwork analysis

- size: single stations
- method: global balance equations.
- output: estimates of the marginal dbns

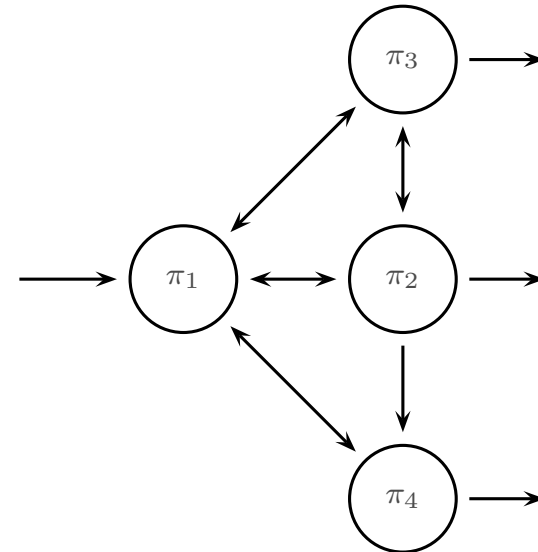

Current objective

Existing methods adapted for multiple server + arbitrary topology:

- revise queue capacities (endogenous)
- modify network topologies (analogy with closed form dbn networks)

Requires:

- approximations to ensure integrality of endogenous capacities
- a posteriori validation (e.g. check positivity)

unsuitable for an optimization framework

Current objective

- multiple server + arbitrary topology + BAS
- preserving initial network configuration (topology + capacities)
- **explicitly** model blocking events

Global balance equations

$$\begin{cases} \pi(i)Q(i) = 0 \\ \sum_{s \in \mathcal{S}(i)} \pi(i)_s = 1 \end{cases}$$

$\pi(i)$: stationary dbn of station i

$Q(i)$: transition rate matrix

$\mathcal{S}(i)$: state space

State space

Upon arrival to a station a job :

- 1 [queue]
- 2 is served (active phase)
- 3 [blocked]
- 4 departs

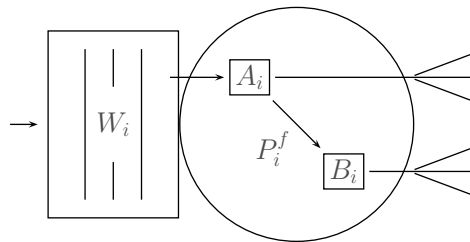

State space of station i :

$$\mathcal{S}(i) = \{(A_i, B_i, W_i) \in \mathbb{N}^3, A_i + B_i \leq c_i, W_i \leq K_i - c_i\}$$

We want to evaluate:

$$\pi(i) = (P((A_i, B_i, W_i) = (a, b, w)), (a, b, w) \in \mathcal{S}(i))$$

Transition rates

$Q(i)$ is a function of:

- λ_i, μ_i : average arrival and service rate
- P_i^f : average blocking probability
- $\tilde{\mu}(i, b)$: average unblocking rate given that there are b blocked jobs

Transition rates

Consider station i which is in state $(A_i, B_i, W_i) = (a, b, w)$.
Then the possible transitions and their rates are:

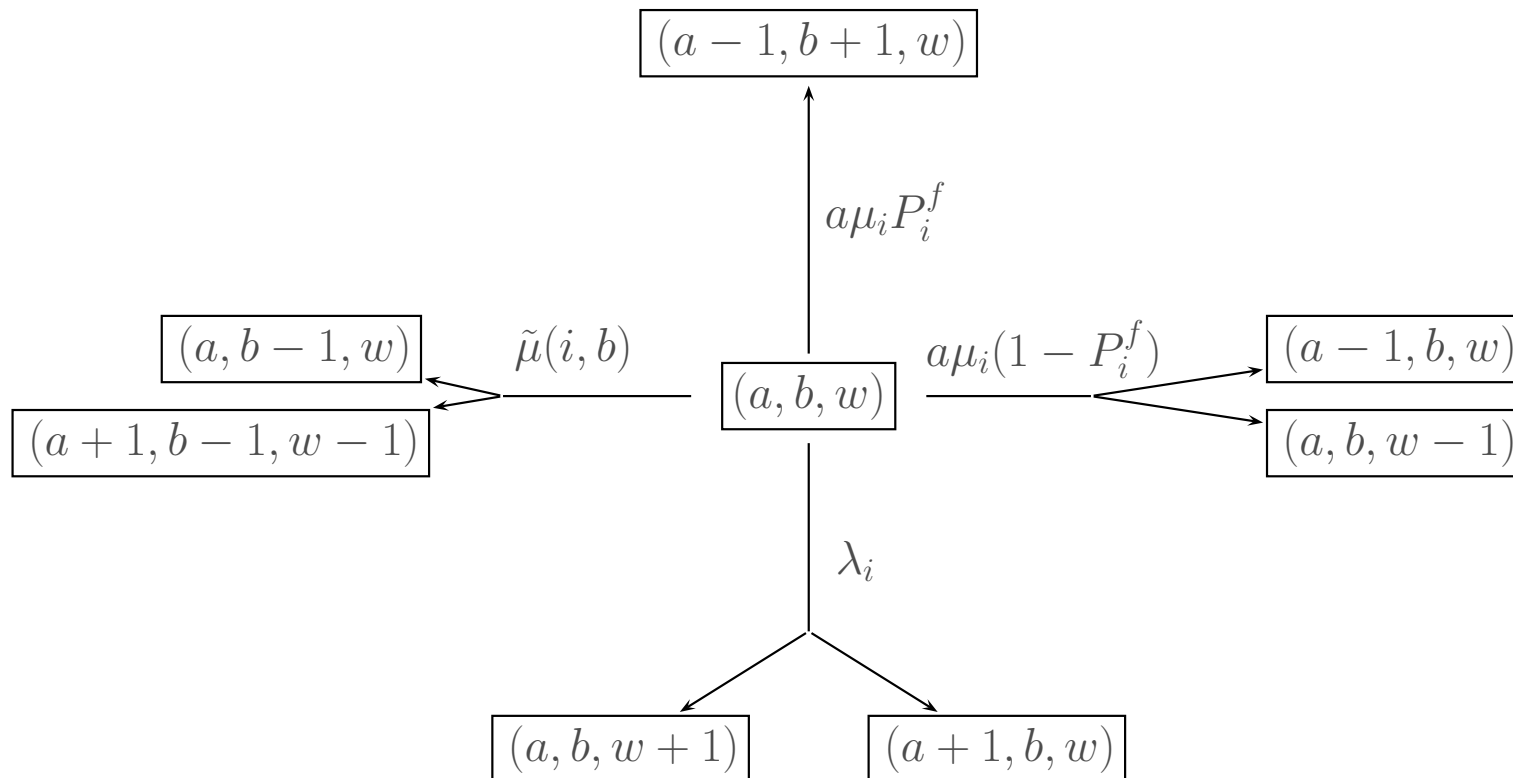

Transition rates

$$Q(i) = f(\lambda_i, \mu_i, P_i^f, \tilde{\mu}(i, b))$$

Main challenge and complexity

Grasping the between station correlation implies appropriately approximating the transition rates between these states.

stationary dbn of each station \leftrightarrow marginal dbn of the station

- approximations used to maintain a tractable model
- classical distributional assumptions

Summary

Aims were:

- decompose the network into single stations
- solve the global balance equations associated to each station:

$$\begin{cases} \pi(i)Q(i) = 0 \\ \sum_{s \in \mathcal{S}(i)} \pi(i)_s = 1 \end{cases}$$

- define $\mathcal{S}(i)$
- approximate $Q(i) = f(\lambda_i, \mu_i, P_i^f, \tilde{\mu}(i, b))$
- approximate the transition rates

Summary

$$\left\{ \begin{array}{l} \pi(i)Q(i) = 0 \\ \sum_{s \in \mathcal{S}(i)} \pi(i)_s = 1 \\ \\ Q(i) = f(\lambda_i, \mu_i, P_i^f, \tilde{\mu}(i, b)) \\ \lambda_i^{\text{eff}} = \lambda_i(1 - P(N_i = K_i)) \\ \lambda_i^{\text{eff}} = \gamma_i(1 - P(N_i = K_i)) + \sum_j p_{ji} \lambda_j^{\text{eff}} \\ P_i^f = \sum_j p_{ij} P(N_j = K_j) \end{array} \right. \quad \left\{ \begin{array}{l} \tilde{\mu}(i, b) = \tilde{\mu}_i^o \phi(i, b) \\ \frac{1}{\tilde{\mu}_i^o} = \sum_{j \in \mathcal{I}^+} \frac{\lambda_j^{\text{eff}}}{\lambda_i^{\text{eff}} \tilde{\mu}_j c_j} \\ \frac{1}{\tilde{\mu}_i} = \frac{1}{\mu_i} + P_i^f \frac{1}{\mu_i^{\text{avg}}} \\ \frac{1}{\tilde{\mu}_i^{\text{avg}}} = \sum_{b \geq 1} \frac{P(B_i = b)}{P(B_i > 0)} \sum_{k=1}^b \frac{k}{b} \frac{1}{\tilde{\mu}(i, k)} \\ P(N_i = K_i) = \sum_{s \in \mathcal{F}(i)} \pi(i)_s \\ P(B_i = b) = \sum_{s=(\cdot, b, \cdot) \in \mathcal{S}(i)} \pi(i)_s \\ P(B_i > 0) = 1 - \sum_{s=(\cdot, 0, \cdot) \in \mathcal{S}(i)} \pi(i)_s \end{array} \right.$$

- Exogenous : $\{\mu_i, \gamma_i, p_{ij}, c_i, K_i, \phi(i, b)\}$
- All other parameters are endogenous
- MATLAB **fsolve** : route for systems of nonlinear equations.

Method validation

Validation versus:

- pre-existing decomposition methods
 - triangular topology
 - tandem two-station
- simulation results on a set of small networks

Excellent results

Case study

Hospital bed blocking: recent demand for modeling and acknowledging this phenomenon:

- patient care and budgetary improvements (Cochran (2006), Koizumi (2005))
- flexibility responsiveness of the emergency and surgical admissions procedure (Mackay (2001)).

The existing analytic hospital network models are limited to:

- feed-forward topologies
- at most 3 units
- Koizumi (2005), Weiss (1987), Hershey (1981).

HUG application

- **Network of interest:** network of operative and post-operative rooms in the HUG, Geneva University Hospital.
- **Dataset**
 - records of arrivals and transfers between hospital units
 - 25336 patient records
Oct 2nd 2004 - Oct 2nd 2005
 - used to estimate γ, μ, p_{ij} (MLE estimators)

Network model:

Unit	BO U	BO OPERA	BO ORL	IF CHIR	IF MED	IM MED	IM NEURO	REV OPERA	REV ORL
c_i	4	8	5	18	18	4	4	10	6

- beds \leftrightarrow servers
- no waiting space \leftrightarrow bufferless ($K_i = c_i$)
- **Validation** of the results vs. DES.

HUG application

Transition probabilities conditional on a patient being blocked

unit id	1	2	3	4	5	6	7	8	9
unit	BO U	BO OPERA	BO ORL	IF CHIR	IF MED	IM MED	IM NEURO	REV OPERA	REV ORL
BO U	-	-	-	0.76	0.04	-	-	0.19	-
BO OPERA	-	-	-	0.59	-	-	-	0.41	-
BO ORL	-	-	-	0.87	0.13	-	-	-	0.01
IF CHIR	0.12	-	-	-	0.02	0.04	0.82	-	-
IF MED	0.11	-	-	0.05	-	0.83	-	-	-
IM MED	0.13	-	-	0.16	0.71	-	-	-	-
IM NEURO	0.34	-	0.01	0.65	-	-	-	0.01	-
REV OPERA	-	-	-	-	-	-	1.00	-	-
REV ORL	-	-	-	0.18	-	-	0.82	-	-

Sources of blocking:

- IF MED \leftrightarrow IM MED
IF CHIR \leftrightarrow IM NEURO
- operating suites: BO U, BO OPERA, BO ORL \rightarrow IF CHIR
- REV OPERA, REV ORL \rightarrow IM NEURO

HUG application

Other performance measures

unit id	1	2	3	4	5	6	7	8	9
unit	BO U	BO OPERA	BO ORL	IF CHIR	IF MED	IM MED	IM NEURO	REV OPERA	REV ORL
K_i	4	8	5	18	18	4	4	10	6
P_i^f	0.02	0.01	0.00	0.06	0.02	0.01	0.01	0.00	0.03
$E[B_i]$	0.04	0.01	0.01	0.22	0.04	0.01	0.01	0.00	0.06
$E[N_i]$	1.37	2.00	0.77	14.03	12.56	2.46	3.19	4.04	0.53
$\frac{1}{\mu_i}$	3.15	3.92	2.99	76.92	66.67	71.43	66.67	4.55	1.93

Blocking may be rare but have a strong impact upon the units:

REV ORL:

- $P_i^f = .03$
- $\frac{E[B_i]}{E[N_i]} = .11$

Current work and aims

- define the optimization framework
- integrate models: analytic + simulator

Problem: optimization of traffic signals

Network:

- Lausanne city center
- SIMLO (AIMSUN) developed in LAVOC
- reduced version
- SIMLO outputs: estimated exogenous parameters ($K_i, p_{ij}, \mu_i, \gamma_i$)

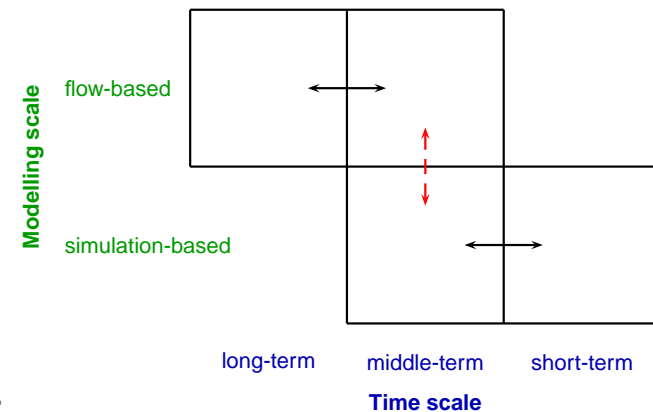

Current work and aims

- define the optimization framework
- integrate: analytic + simulator

The implementation of the methodology will be carried out in 2 steps:

1. Develop and test the methodology
 - DES developed in TRANSP-OR
 - simple to manipulate
 - has been validated
2. Apply the methodology
 - use an application-specific simulator within the framework
 - AIMSUN

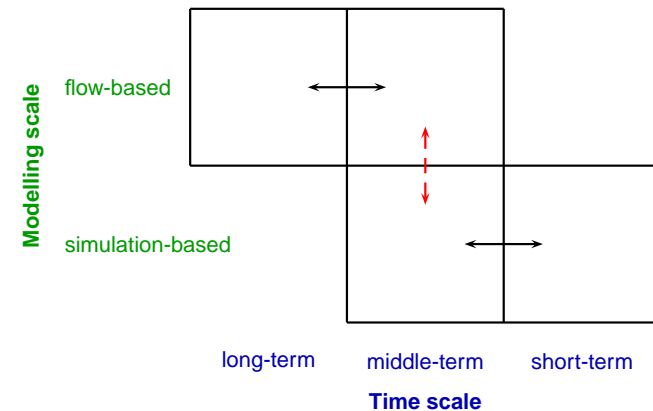

Conclusions

- a decomposition method allowing the analysis of FCQN
- explicitly models the blocking phase
- preserves network topology and configuration
- validation versus both pre-existing methods and simulation estimates shows encouraging results
- application on a real case study
- work in progress: optimization framework definition and implementation